

# ACTIVE

## INDOOR AIR PURIFICATION

# SUBMITTAL

The Dust Free® Active is designed to be installed into an existing HVAC system for improved indoor air quality. Please read and follow all service procedures outlined in the manual.

**Dimensions:** See Fig.1

**Weight:**  
3 lbs.

**Warranty:**  
7-yr power module. 4-yr core. 2-yr lamp.

**Electrical:**

The unit uses an electronic power module. The device must be installed in compliance with all national and local electrical and mechanical codes.

24V (Expanded range ballast: 20V-32V),  
50/60Hz, 1.4A. 3000V surge protection.

**Temperature:**

45 F - 150 F (Outside of duct).

**Airflow:**

6" Unit - Up to 2000 CFM.  
12" Unit - Up to 3000 CFM.

Air flow specification subject to pollutant levels.

Fig. 1 Dimensions of unit.

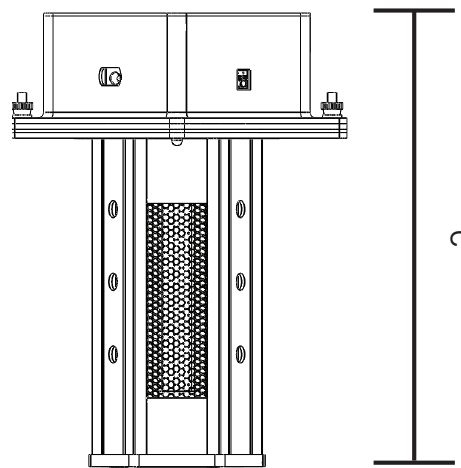
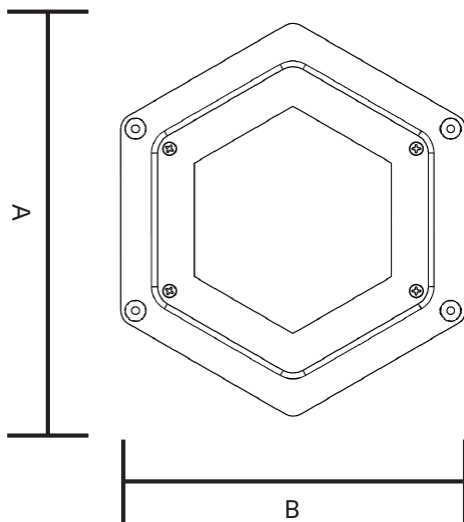

MODEL	DIM. A	DIM. B	DIM. C
6" Unit	8"	7"	9.5"
12" Unit	8"	7"	14.5"
M. Plate	8"	7"	

Specifications subject to change without notice.

**EPA Establishment No. 73316-TX-1**

Dust Free® uses independent labs and universities for product testing. Visit <http://www.dustfree.com/testing>.

The product and technologies described are not medical devices, and are not intended to diagnose, treat, cure, or prevent any disease or illness.

Date: \_\_\_\_\_

Engineer: \_\_\_\_\_

Job Name: \_\_\_\_\_

Contractor: \_\_\_\_\_

Location: \_\_\_\_\_

Submitted By: \_\_\_\_\_

