

BIO-FIGHTER® Ultra-Flex 1S and 2S Ultraviolet Light Systems

Installation & Operation Manual

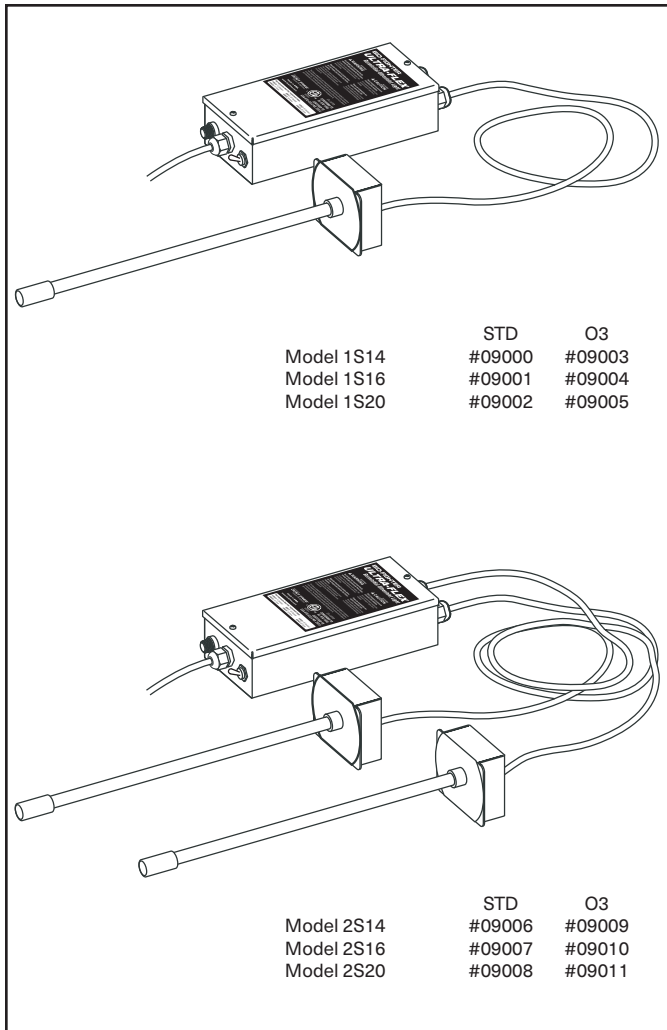

FEATURES

- Compact chassis design.
- Remote-mount lamp configuration.
- 6-ft remote lamp cables.
- Multi-input voltage electronic ballast.

INCLUDED INSIDE BOX

- Bio-Fighter® Ultra-Flex UV-C system
- Viewport(s)
- Self-drilling screws
- Installation & operation manual
- UV warning label for duct
- Registration card

TOOLS REQUIRED FOR INSTALLATION

- Electric drill
- Phillips screw bit or screwdriver
- 1/2" drill bit
- 1" drill bit or holecutter
- Eye protection

BEFORE INSTALLING

- Read all instructions carefully. Failure to do so could damage the equipment or cause harm to yourself or others.
- Acknowledge all warnings.
- Only qualified technicians should perform the installation.



Dimensions

9.25" L x 4" W x 2" H

Weight:

Approx. 4 lbs.

Electrical:

120V-240V, 50/60Hz, 1PH. 3 amp-250V fuse.
6 ft. power cord.

U.S. Patent Nos. 5,334,347, 5,817,276, 6,245,293, 6,267,924,
6,280,686, 6,313,470, 6,627,000, 6,539,727, 6,932,494, 6,550,257.

Specifications subject to change without notice.

EPA Establishment No. 73316-TX-1

Visit <http://www.dustfree.com/testing> for a list of micro-organisms inactivated by Dust Free® products.

The product and technologies described are not medical devices, and are not intended to diagnose, treat, cure, or prevent any disease or illness.



ETL LISTED
CONFORMS TO
UL STD 1598
CERTIFIED TO
CSA STD C22.2 NO. 250.0

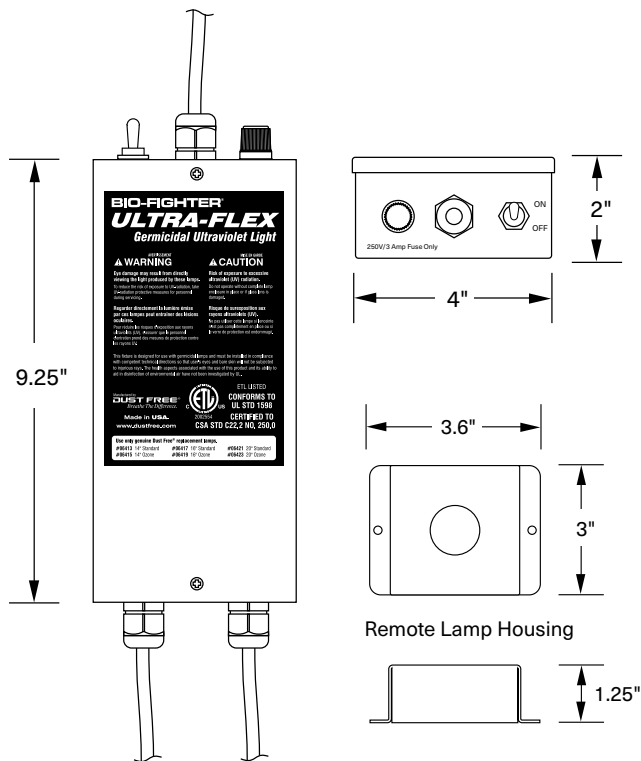

REMOTE LAMP MOUNTING LOCATION

Select a mounting location with enough clearance for the lamp to be installed and replaced easily. Allow approximately 15"-21" depending on lamp length.

A 120V or 240V electrical supply is required.

Special Installation Notes

- Do not install in closet return grille applications.
- Do not install in outdoor applications.
- Do not expose wiring or plastic parts to UV-C light.
- Do not install where UV-C light can be seen after installation.
- Do not install beneath a humidifier.
- If the UV device is installed on the inlet side (return air side) of a coil, make sure that the HVAC system is configured such that the blower is located between the return air filter and the inlet side (return air side) of the coil, such as would be found in a traditional up-flow, or horizontal furnace with the coil placed after the heat exchanger.
- If the UV device is installed near an air filter, check with filter manufacturer for UV-C resistance properties.
- If the desired UV installation location is intended to irradiate an air filter, to neutralize the microbiological matter on the air filter surface, such as would be found in the return air drop of a basement application or in the return plenum of a horizontal system in an attic; take precautions as described in note above, and make sure the UV fixture is placed on the return side of the filter. **DO NOT INSTALL THE UV FIXTURE ON EITHER SIDE OF THE FILTER IN HALL / CLOSET RETURN AIR APPLICATIONS.** (See ATTENTION! Warning sheet #212945-00).

⚠ CAUTION
UV-C Light May Degrade Plastic and Rubber.
Shield exposed plastic drain pans, wire insulation, flex duct, or other plastic/rubber components from UV-C light.

Important:

The device must be installed in compliance with all national and local electrical and mechanical codes. Failure to do so will void Dust Free® warranty.

MOUNTING THE BASE (Fig.1)

Remove the cover and place the base at the desired location. Use the included mounting screws to install the base to the surface.

Replace the cover after the base is mounted.

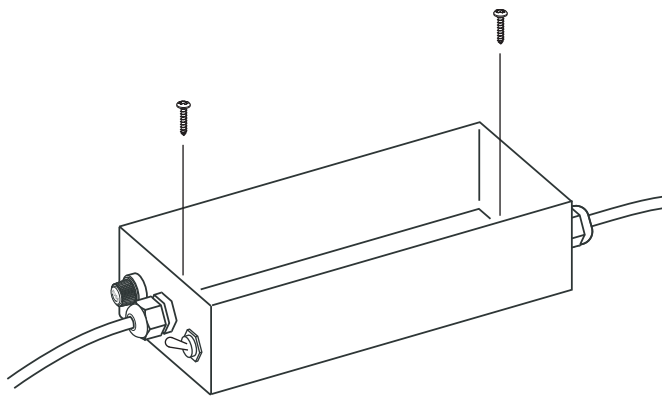

Fig. 1 Use included mounting screws to install device at desired location.

REMOTE LAMP BASE MOUNTING (Fig.2)

Remove the remote lamp housing from the remote lamp base by removing the knurled nuts. Then install the remote lamp base to the surface with the included mounting screws. Using the remote lamp base as a template, drill a 1" hole for the lamp.

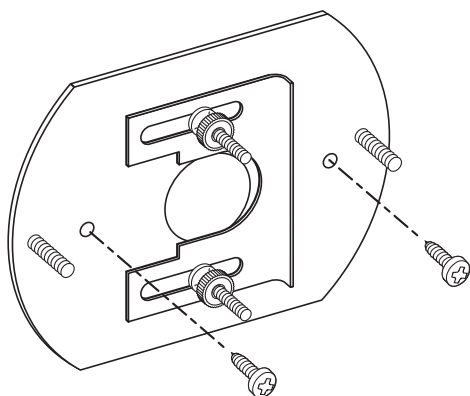

Fig. 2 Lamp is secured with a sliding bracket tightened with two knurled nuts.

INSTALLING THE LAMP (Fig.3)

To maximize the efficiency and life of the UVC lamp, clean each lamp prior to installation. Use isopropyl alcohol and cotton cloth to wipe dust and fingerprints from the lamp.

Gently insert the lamp into the lamp hole. Slide the bracket over the retaining lip of the lamp and tighten the two knurled nuts until the lamp is securely fastened. The lamp seals against the base of the unit using a rubber grommet which prevents air leaks. Repeat for each lamp of the installation.

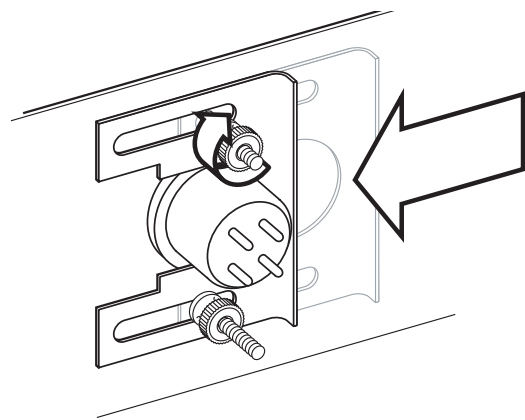

Fig. 3 Lamp is secured with a sliding bracket tightened with two knurled nuts.

⚠ NOTICE

Clean lamp(s) prior to installation.

Failure to remove dirt and fingerprints from the lamp(s) could shorten their lifespan.

⚠ WARNING

UV-C Light Hazard.

UV-C light can cause temporary or permanent loss of vision, and sunburn. To prevent exposure, do not install device in any applications that allows UV-C light to be visible after installation.

⚠ CAUTION

Sharp Edge Hazard.

Be careful of sharp edges on device and HVAC equipment while installing the device. Personal injury may result.

INSTALLING THE LAMP HOUSING(s)

(Fig.4)

After lamp has been installed, reinstall the remote lamp housing using the knurled nuts. The remote lamp housing must be in place prior to attaching the electrical harness.

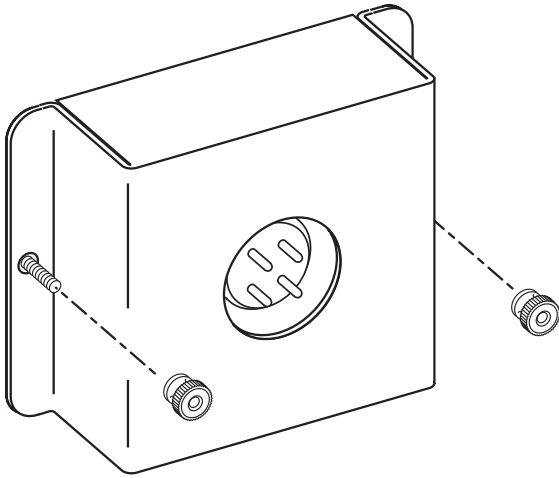

Fig. 4 Reinstall lamp housing.

CONNECTING THE HARNESS (Fig.5)

With the lamp housing in place attach the connector to the lamp. Hold back the protective boot to expose the harness connector. The harness connector is asymmetrical and can only be attached one way. If the harness does not attach easily, rotate 90 degrees and try again. After the harness connector is attached, slide the protective boot over the lamp/connector. The protective boot fits snugly over the lamp and seals the connection from moisture, dust, etc.

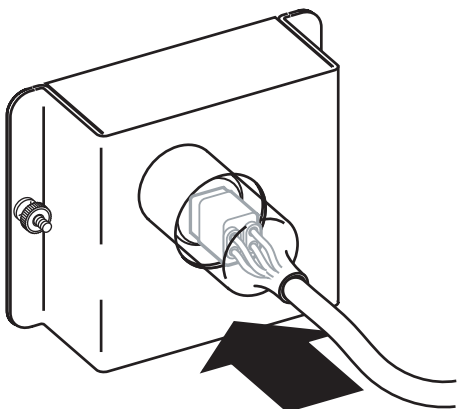

Fig. 5 Attach lamp harness to lamp. The plastic boot slips over the lamp and seals the connection from moisture.

INSTALLING THE AHU VIEWPORT(s)

The Ultra-Flex comes with UV-C safe viewports that must be installed separately. To install the viewport, select a location near the lamp installation and drill a 1/2" hole in the duct. Then press the viewport into the hole.

CONNECT POWER AND CHECK OPERATION

Connect the device to 120V-240V power. (Fig.6)

The device power switch must be turned on and device checked for operation using the viewport(s). The lamp(s) should be radiating a bright blue light.

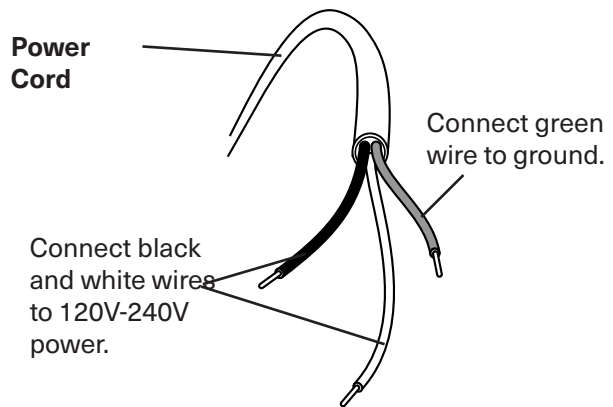

Fig. 6 Power cord connection.

OPERATION

Under normal conditions the Bio-Fighter® Ultra-Flex should be operated continuously to extend the life of the lamp(s), and to increase the effectiveness in disinfecting the location selected. A convenient power switch is located on the device, and should be turned off before any maintenance on the device or HVAC system is performed.

⚠ WARNING

UV-C Light Hazard.

UV-C light can cause temporary or permanent loss of vision, and sunburn. Take precautions to protect eyes and skin from direct exposure.

TROUBLESHOOTING

Maintenance and troubleshooting should be performed by a qualified technician.

Device fails to operate. Check the following:

1. Device is connected to proper power.
2. Fuse is in good working order. Replace the fuse if necessary.
3. Ballast is receiving correct power. Replace ballast if necessary.
4. Continuity of lamp filaments. (Replace lamp if necessary.)
5. Wires are properly connected to lamp and ballast.
6. Lamp is properly connected to lamp receptacle.

FUSE REPLACEMENT

1. Turn off power to the equipment.
2. Unscrew the knob marked "Fuse" and remove fuse.
3. Install new fuse and screw knob back in place. Be sure O-ring is in place when used in wet locations. Only use a 250V/3 amp fuse.
4. Turn on power to the equipment.

PROPER CLEAN-UP TECHNIQUE IN CASE OF LAMP BREAKAGE

- Wear protective gloves, eyewear and mask.
- Sweep the broken glass and debris into a plastic bag, seal the bag, and dispose of properly. Contact your local waste management office for proper disposal.
- **Do not use a vacuum cleaner. Do not incinerate.**

WARNING

Burn Hazard.

During replacement, allow lamps to cool 10 minutes before removing them. Personal injury may result.

WARNING

Mercury Hazard. Do Not Break.

Each UV-C lamp contains a small amount of Mercury. May cause redness or irritation. Use proper disposal techniques in case of breakage.

LAMP REPLACEMENT (Annually)

The lamp should be replaced annually even if it appears to be operating normally. UV-C energy production diminishes over time.

1. Obtain the correct replacement lamp for your model.
2. Disconnect power to the equipment.
3. Open the cover of the device. Allow lamp to cool 10 minutes before touching.
4. Disconnect the electrical connector to the lamp.
5. Remove the remote lamp housing.
6. Unscrew the two knurled nuts of the lamp retaining bracket and slide the bracket away from the lamp retaining lip.
7. Carefully remove the UV-C lamp and replace it with the new lamp. Be sure to clean the lamp of dust and fingerprints prior to installation.
8. Slide the retaining bracket back in place and tighten knurled nuts.
9. Reattach the remote lamp housing. The remote lamp housing must be in place prior to attaching the electrical connector.
10. Reconnect electrical connector to the lamp.
11. Reconnect power.
12. Verify operation using viewport.

LAMP DISPOSAL

Dispose of your spent UV-C lamps at your local recycling center. You may also send your spent lamps in the same container you received your replacement lamps to:

Dust Free® Lamp Reclamation
1112 Industrial Drive
Royse City, TX 75189

WARNING

UV-C Light Hazard.

UV-C light can cause temporary or permanent loss of vision, and sunburn. Take precautions to protect eyes and skin from direct exposure.

Replacement Parts	Part No.
UVC Lamp - 14"06413
UVC Lamp - 16"06417
UVC Lamp - 20"06421
UVC-O3 Lamp - 14"06415
UVC-O3 Lamp - 16"06419
UVC-O3 Lamp - 20"06423
Ballast - Multi-Voltage06426
Power Cord Whip-Type06303
On/Off Switch06617
Slide Bracket Springs (2)	210-0005-001
Slide Bracket210929-00
Knurled Nuts (2)210226-00
Fuseholder212225-00
Fuse	750-0108-001

For information on the dealer in your area call: 1-972-635-9564.
 Visit us at <http://www.dustfree.com>

LIMITED WARRANTY

Dust Free LP warrants this Bio-Fighter UV-C Light to be free from defects in materials and workmanship under normal use and service, for as long as it is owned by the original purchaser. This warranty does not cover UV-C lamp(s), which carry a one (1) year warranty from the date of installation, or the ballast which carries a five (5) year warranty.

This warranty does not cover cosmetic damage, damage due to acts of God, damage as a result of handling or shipment, negligence, misuse, connection to improper voltage, improper maintenance, or abuse. This warranty is void if defect(s) result from failure to have this unit installed by a qualified, properly licensed, heating and air conditioning contractor in compliance with all local building and construction codes.

Dust Free LP's exclusive obligation under this warranty shall be to supply, without charge, a replacement for any covered component of the Bio-Fighter UV-C Light which is found to be defective within the parameters defined herein. Dust Free LP reserves the right to replace or repair the defective part or component.

DUST FREE LP SHALL NOT BE LIABLE FOR ANY LOSS OR DAMAGE OF ANY KIND, INCLUDING ANY INCIDENTAL OR CONSEQUENTIAL DAMAGES RESULTING, DIRECTLY OR INDIRECTLY, FROM ANY BREACH OF WARRANTY, EXPRESS OR IMPLIED, OR ANY OTHER FAILURE OF THIS PRODUCT. (Some states do not allow the exclusion or limitation of incidental or consequential damages, so this limitation may not apply to you.) THE WARRANTIES SET FORTH HEREIN ARE EXCLUSIVE AND DUST FREE LP EXPRESSLY DISCLAIMS ALL OTHER WARRANTIES, WHETHER WRITTEN OR ORAL, IMPLIED OR STATUTORY, INCLUDING BUT NOT LIMITED TO ANY WARRANTIES OF MERCHANTABILITY, WORKMANSHIP, OR FITNESS FOR A PARTICULAR USE. If the limited warranty is void due to failure to use a qualified contractor all disclaimers of implied warranties shall be effective upon installation.

How to make a warranty claim or have questions answered:

Should you have a warranty claim or questions about the warranty policy, contact the distributor or dealer from which you purchased the product. Proof of original purchase and proof of identity that the original purchasing party is filing the claim is required in order to initiate a warranty claim. Defective parts must be returned no later than thirty (30) days after the failure to the installing contractor together with the model number, serial number, and date of installation. All service and removal must be performed by a licensed HVAC contractor. You must pay shipping charges and all other costs of warranty service. Warranty is only valid the United States and Canada.

THIS WARRANTY SHALL NOT OBLIGATE THE MANUFACTURER FOR ANY LABOR COSTS AND SHALL NOT APPLY TO DEFECTS IN WORKMANSHIP OR MATERIALS FURNISHED BY THE INSTALLING CONTRACTOR AS CONTRASTED TO DEFECTS IN THE GERMICIDAL LIGHT ITSELF.

NOTE: Do not return any products or parts to the factory without a factory issued Return Authorization number issued by the Dust Free LP customer service department.

In the event you have any questions concerning the use and care of this product or this warranty which have not been answered to your satisfaction by the distributor or dealer, please call or write the factory.

Dust Free®
PO Box 519
1112 Industrial Drive
Royse City, TX 75189
1-972-635-9565